

DIMENSIONS

BHO CONCEALED CEILING

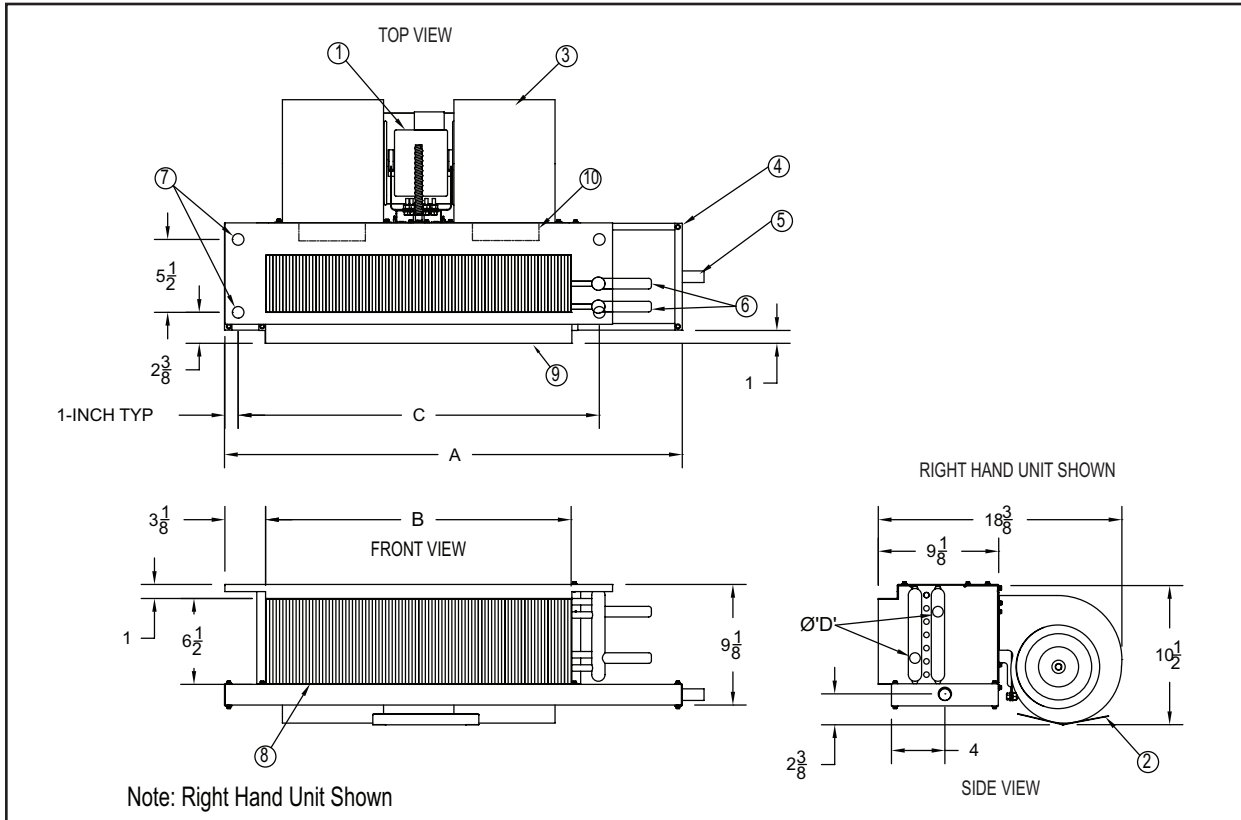

- 1. Motor
- 2. Motor under protection plate
- 3. Motor/Blower(s) Assembly
- 4. Condensate Tray (Double Wall optional)
- 5. Condensate Copper Connection $\frac{3}{4}$ " MNPT
- 6. Coil Connections (2-Pipe Shown)
- 7. Installation Hanging Points
- 8. Coil
- 9. Supply Air Flange
- 10. Electric Heaters (optional)

Model	Dimensions (inches)				Approx. Weight (pounds)
	A	B	C	D	
BHO02	25½	14¼	18¼	5⁄8	43
BHO03	28½	17¼	21¼	5⁄8	52
BHO04	34½	23¼	27¼	5⁄8	65
BHO06	43½	32¼	36¼	5⁄8	76
BHO08	51½	40¼	44¼	5⁄8	85
BHO10	61½	50¼	54¼	7⁄8	115
BHO12	71½	60¼	64¼	7⁄8	118

All dimensions are in inches.