

DIMENSIONS

BHC EXPOSED CABINET

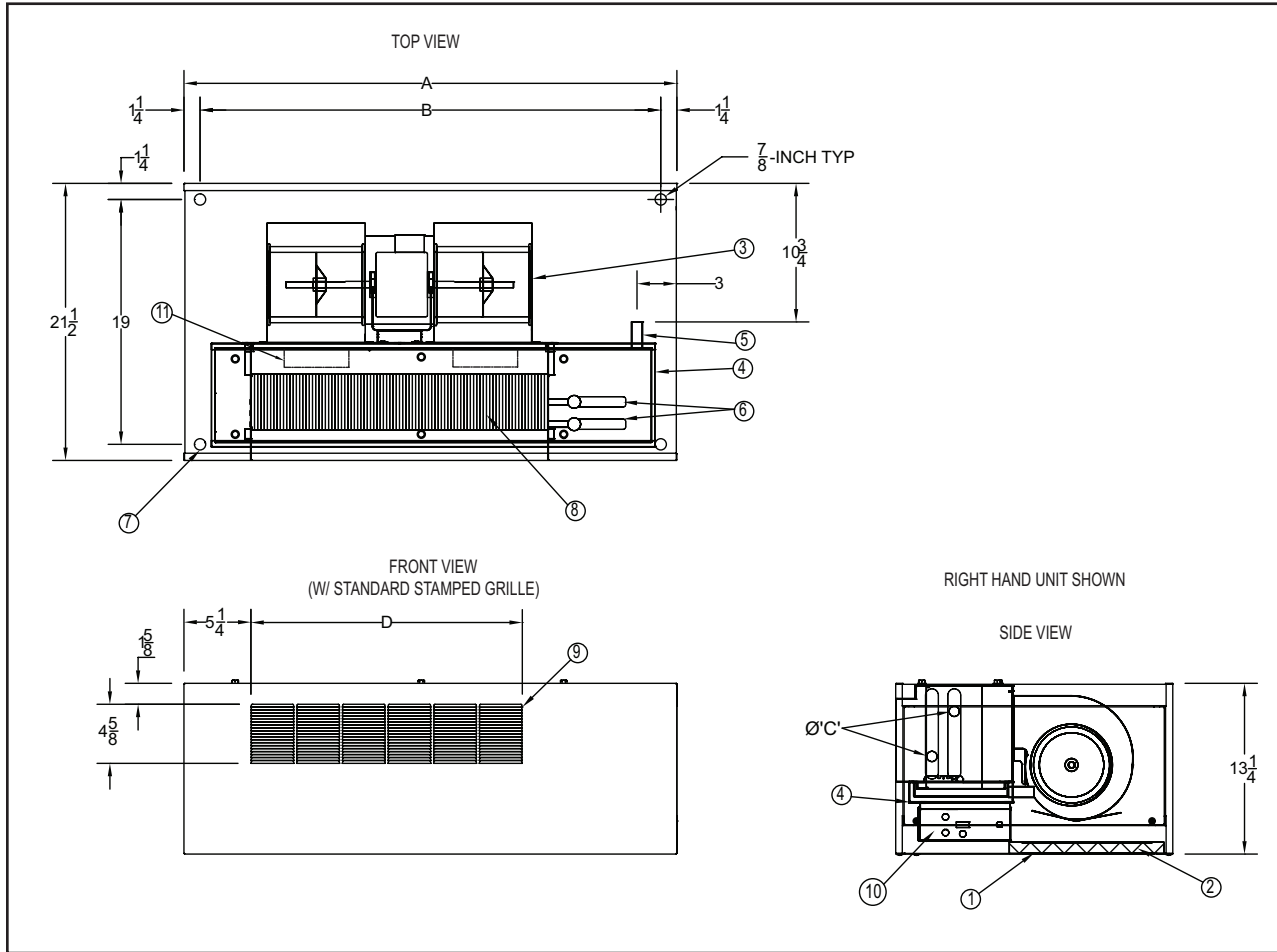

- | | | |
|--|---|---------------------------------|
| 1. Access Panel w/ Return Air Stamped Grille | 4. Condensate Tray (Double Wall optional) | 8. Coil |
| 2. Filter | 5. Condensate Connection 3/4" MNPT | 9. Discharge Air Stamped Grille |
| 3. Motor/Blower(s) Assembly | 6. Coil Connections (2-Pipe Shown) | 10. Electric Control Panel |
| | 7. Hanging Points | 11. Electric Heaters (optional) |

Model	Dimensions (inches)					Approx. Weight (pounds)
	A	B	C	D	Filter	
BHC02	29 1/4	26 3/4	5/8	14	16x12x1	98
BHC03	32 1/4	29 3/4	5/8	15 11/16	24x12x1	112
BHC04	38 1/4	35 3/4	5/8	21 1/16	29x12x1	126
BHC06	47 1/4	44 3/4	5/8	31 13/16	38x12x1	144
BHC08	55 1/4	52 3/4	5/8	39 1/8	46x12x1	165
BHC10	65 1/4	62 3/4	7/8	49 1/2	(2) 28x14x1	196
BHC12	75 1/4	72 3/4	7/8	60	(2) 31x14x1	221

All dimensions are in inches.