

DIMENSIONS

AHO CONCEALED CEILING

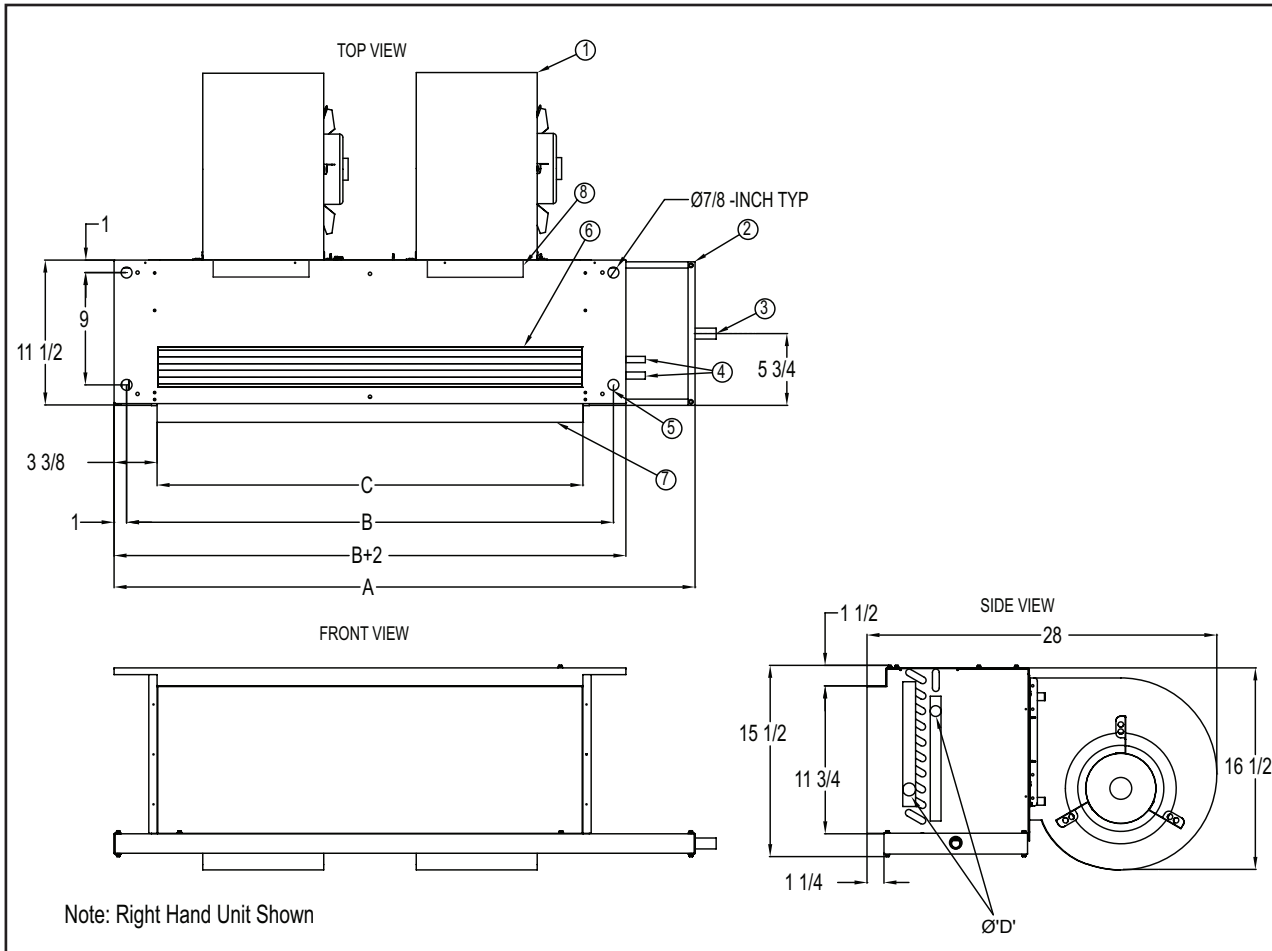

- 1. Motor/Blower(s) Assemblies
- 2. Condensate Tray (Double Wall)
- 3. Condensate Connection 3/4" MNPT
- 4. Coil Connections (2-Pipe Shown)
- 5. Installation Hanging Points
- 6. Coil
- 7. Supply Air Flange
- 8. Electric Heaters (optional)

Model	Dimensions (inches)				Approx. Weight (pounds)
	A	B	C	D	
AHO06	25 1/2	18	13	5/8	60
AHO08	30 1/2	23	18	5/8	69
AHO10	33 1/2	26	21	7/8	75
AHO12	38 1/2	31	26	7/8	99
AHO14	42 1/2	35	30	7/8	108
AHO16	46 1/2	39	34	7/8	115
AHO18	51 1/2	44	39	7/8	125
AHO20	55 1/2	48	43	7/8	175

All dimensions are in inches.