

DIMENSIONS

BVC FLAT TOP CABINET

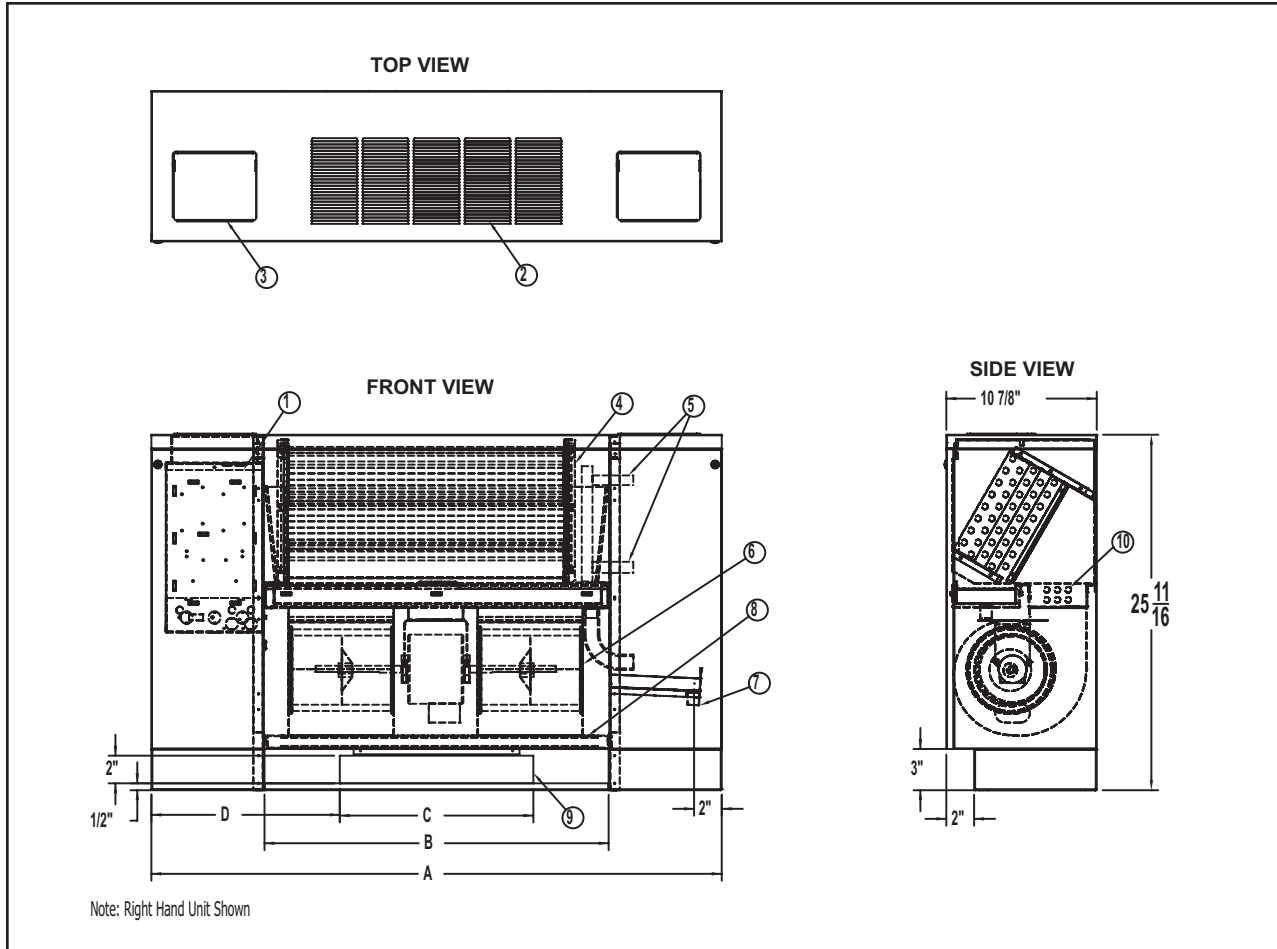

- 1. Control Box
- 2. Stamped Supply Air Grille
- 3. Control Access Door
- 4. Coil
- 5. Coil Connections (2-Pipe Shown)
- 6. Motor/Blower(s) Assembly
- 7. Condensate Connection.
- 8. Filter
- 9. Fresh Air Damper Opening (optional) = 2" x "C"
- 10. Electric Heaters (optional)

Model	Dimensions (inches)					Approx. Weight (pounds)
	A	B	C	D	Filter	
BVC02	34 1/4	18	12	11 1/8	17x10x1	95
BVC03	37 1/4	21	12	12 5/8	20x10x1	104
BVC04	41 1/4	25	12	14 5/8	24x10x1	106
BVC06	52 1/4	36	24	14 1/8	35x10x1	128
BVC08	60 1/4	44	24	18 1/8	43x10x1	146
BVC10	70 1/4	54	36	17 1/8	(2)26x10x1	178
BVC12	80 1/4	64	36	22 1/8	(2)31x10x1	186

All dimensions are in inches.