

DIMENSIONS

BVR CONCEALED FLOOR

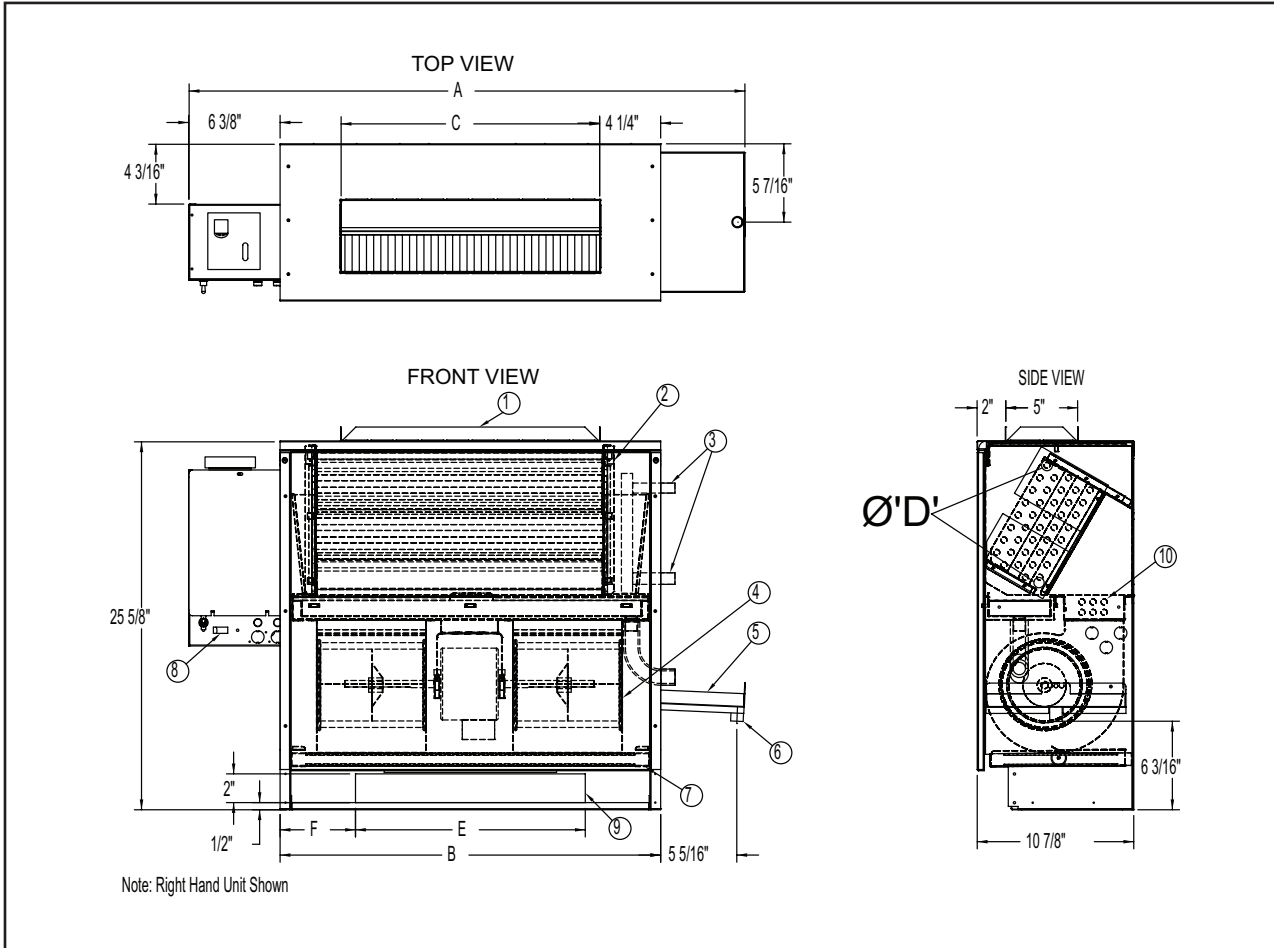

- 1. Supply Air Flange = "C"
- 2. Coil
- 3. Coil Connections (2-Pipe Shown)
- 4. Motor/Blower(s) Assembly
- 5. Auxiliary Condensate Tray
- 6. Condensate Connection
- 7. Filter
- 8. Control box
- 9. Fresh Air Damper Opening (optional) = 2" x "E"
- 10. Electric Heaters (optional)

| Model | Dimensions (inches) | | | | | | | Approx. Weight (pounds) |
|-------|---------------------|--------|----|-----|----|--------|------------|-------------------------|
| | A | B | C | D | E | F | Filter | |
| BVR02 | 31 3/4 | 19 1/2 | 11 | 5/8 | 12 | 3 3/4 | 17x10x1 | 63 |
| BVR03 | 34 3/4 | 22 1/2 | 14 | 5/8 | 12 | 5 1/4 | 20x10x1 | 70 |
| BVR04 | 38 3/4 | 26 1/2 | 18 | 5/8 | 12 | 7 1/4 | 24x10x1 | 80 |
| BVR06 | 49 3/4 | 37 1/2 | 29 | 5/8 | 24 | 6 3/4 | 35x10x1 | 99 |
| BVR08 | 57 3/4 | 45 1/2 | 37 | 5/8 | 24 | 10 3/4 | 43x10x1 | 106 |
| BVR10 | 67 3/4 | 55 1/2 | 47 | 7/8 | 36 | 9 3/4 | 2(26)x10x1 | 136 |
| BVR12 | 77 3/4 | 65 1/2 | 57 | 7/8 | 36 | 14 3/4 | 2(31)x10x1 | 150 |

All dimensions are in inches.