

# SSL & SBS Installation Manual



SO TOUGH,  
WE GUARANTEE IT.



/// SSL

/// SBS

## Table of Contents

TABLE OF CONTENTS.....	2
SAFETY SYMBOLS .....	2
SAFETY CONSIDERATIONS.....	3
PRE START-UP .....	4
Receiving and Inspecting .....	4
Unit Rigging and Placement.....	4
Clearance .....	4
FIELD WIRING .....	4
BELTS, DRIVES, AND BEARINGS .....	5
DETERMINING DEFLECTION FORCE .....	5
REPLACEMENT PARTS .....	6
PIPING .....	6
CONDENSATE DRAIN AND TRAPS .....	7
GENERAL BELT AND BEARING MAINTENANCE .....	8
MOTOR ELECTRICAL DATA .....	9
UNIT WEIGHT DATA.....	9
MOTOR/DRIVE WEIGHT DATA.....	9
MODEL SSL ARRANGEMENTS .....	10
MODEL SBS ARRANGEMENTS.....	10
INSPECTION & START-UP CHECKLIST.....	11
DIMENSIONS.....	12
Model SSL Basic Unit - Discharge Arrangement 2.....	12
Model SSL Basic Unit - Discharge Arrangement 1 with Blow-thru Electric Heat.....	13
Model SBS Basic Unit - Discharge Arrangement 2 .....	14
Model SSL/SBL with Mixing Box Inlet Damper Section (Requires Base rail) - Discharge Arrangement 2.....	15
3 Inch Baserail Assembly.....	16
Model SSL/SBS Discharge Plenum, Sizes 08-30 .....	17
Model SSL Return Plenum, Sizes 08-30 .....	18
Model SSL/SBS Discharge Section w/ Heating Coil, Sizes 08-30 .....	19





## SAFETY SYMBOLS

The following symbols are used in this document to alert the reader to areas of potential hazard:

	indicates an imminently hazardous situation which, if not avoided, will result in death or serious injury
danger	
	indicates a potentially hazardous situation which, if not avoided, could result in death or serious injury
warning	
	identifies a hazard which could lead to damage to the machine, damage to other equipment and or environmental pollution. Usually an instruction will be given, together with a brief explanation
caution	
	is used to highlight additional information which may be helpful to you
note	

The equipment covered by this manual is designed for safe and reliable operation when installed, operated, and maintained within its design specifications. To avoid personal injury or damage to equipment or property during installation, operation, and maintenance of this equipment, it is essential that these functions be performed by qualified, experienced personnel using good judgment and safe practices. See the following cautionary statements.

 **ELECTRICAL SHOCK HAZARDS.** All power must be disconnected prior to installation and servicing of this equipment. More than one power source may be present. Disconnect all power sources to avoid electrocution or shock injuries.

 **MOVING PARTS HAZARDS.** Power must be disconnected from the motor and blower prior to opening access panels. Motors can start automatically, and more than one power source may be present. Disconnect all power and control circuits prior to servicing to avoid serious crushing or dismembering injuries.

 **HOT PARTS HAZARDS.** Hot water and steam heating coils operate at temperatures that will cause severe burn injury. Some systems will continue to allow circulation of hot water, even with all control circuits de-energized. Before performing service at or near any heating coil, piping, or valve package component, disconnect all power and close all isolation valves, and allow the equipment to cool. As previously mentioned, more than one power source may be present.

 Electric resistance heating elements may start automatically. Disconnect all power and control circuits, and allow the elements to cool before servicing. Again, more than one power source may be present.

 Check that the unit assembly and component weights can be safely supported by rigging and lifting equipment.

 All assemblies must be adequately secured during lifting and rigging by temporary supports and restraints until equipment is permanently fastened and set in its final location.

 All unit temporary and permanent supports must be capable of safely supporting the equipment's weight and any additional live or dead loads that may be encountered. All supports must be designed to meet applicable local codes and ordinances.

 All fastening devices must be designed to mechanically lock the assembly in place without the capability of loosening or breaking away due to system operation and vibration.

 Secure all dampers when servicing damper, actuator or linkages. Dampers may activate automatically to disconnect control circuits to avoid injury.

 Protect adjacent flammable materials when brazing. Use flame and heat protection barriers where needed. Have fire extinguisher available and ready for immediate use.

 Never wear bulky or loose-fitting clothing when working on any mechanical equipment. Gloves should only be worn when required for proper protection from heat or other possible injury. Safety glasses or goggles should always be worn when drilling, cutting, or working with chemicals such as refrigerants or lubricants.

 Never pressurize any equipment beyond specified test pressures. Always pressure test with some fluid or inert gas such as clear water or dry nitrogen on refrigeration systems to avoid possible damage or injury in the event of a leak or component failure during testing.

 The manufacturer assumes no responsibility for personal injury or property damage resulting from improper or unsafe practices during the handling, installation, service or operation of any equipment.

## PRE START-UP



Improper installation, adjustment, alterations, service or maintenance can cause injury and property damage, as well as possible voiding of factory warranty. For assistance or additional information, consult a qualified contractor.

## Receiving and Inspecting

Thoroughly examine the exterior and interior of all units for transportation damage to the cabinet, piping, blower(s), motor(s), coil(s), electric heat and electrical components. Interior damage may occur, even with no visible exterior damage. If damage is found, immediately file a claim with the carrier. Note the damage on the bill of lading before signing for the shipment.

Check the bill of lading for verification that all items shown (including loose items) have been received. Notify the manufacturer's representative of any shortages or items shipped in error.

## Unit Rigging and Placement

Install ductwork to comply with ASHRAE Fundamentals Handbook, SMACNA, NFPA 90A and local code.

The installation must conform with local building codes and the National Electric Code.

Locate unit support in accordance with the mechanical and structural plans. If so equipped, locate the isolator placement and correct size as shown on the submittal drawing.

Ceiling suspension of horizontal units have factory provisions for thru bolt hanger rods, except double wall units (which require external rigging). If floor mount isolators are required for either horizontal or vertical units, then factory or field provisions must be made for isolator attachment. Vertical units can be mounted directly to the floor or on a base rail. For units with isolators but no base rail, 6" legs are required and will need to be mounted to the base of the unit. If a base rail is provided, isolators can be installed in mounting holes provided on this base rail.

Do not handle the unit using coil stubout connectors, as damage may occur at brazed joint(s).

## Clearance

All units, including those with electric heat, are listed for zero clearance to combustibles.

Sufficient clearance for normal servicing of this equipment is recommended.

All electrical panels must have 36" working space in front of panel to meet National Electric Code; however, local inspectors may waive this requirement if the hinged cover has a 90° free swing.

## FIELD WIRING



Prior to installing any wiring, check the unit nameplate for main power voltage, control voltage, transformer sizing and any fuse sizing. All field wiring must comply with National Electric Code and local code requirements.

Tighten all wiring lugs and terminals prior to connecting power to the unit, as they may loosen during transportation.

Route the power lines to the power distribution terminals inside the control enclosure. If a factory wired disconnect switch is installed, then connect the power lines to the line side of the switch.

Mount and wire any field installed items as indicated on the factory supplied wiring diagram. When mounting field installed components, do not jumper out or rewire any factory wiring without written approval from Superior Rex. Violation will void warranty.

# New Blower Coils – IOM

## BELTS, DRIVES, AND BEARINGS



For safety, please turn off all power before checking belt tension.

Prior to starting the unit, tighten all set screws on the fan(s), sheaves and bearings where applicable. Set screws may loosen during transportation.

Sheaves must be in line. Use a straight edge to verify.

General belt tension rules for V-Belt drives:

- Ideal tension is the lowest tension at which the belt will not slip under peak load conditions.
- Check tension frequently during the first 24-48 hours of operation.
- Over tensioning shortens belt and bearing life.
- Keep belts free from foreign material which may cause slip.
- Make V-Belt inspection on a periodic basis. Tension when slipping. Never apply belt dressing, as this will damage the belt and cause early failure.
- The resilient blower bearing must not deflect laterally once belt is tightened.

## DETERMINING DEFLECTION FORCE

(see Fig. 1)

EXAMPLE	SOLUTION
Belt Span = 20" Belt Type – A, new, unnotched RPM = 1000 Small Sheave Diameter = 4.0"	$Deflection = 20 \div 64 = .313"$ (round to 5/16"). Referring to table below, deflection force at calculated deflection is 6.8lbs.

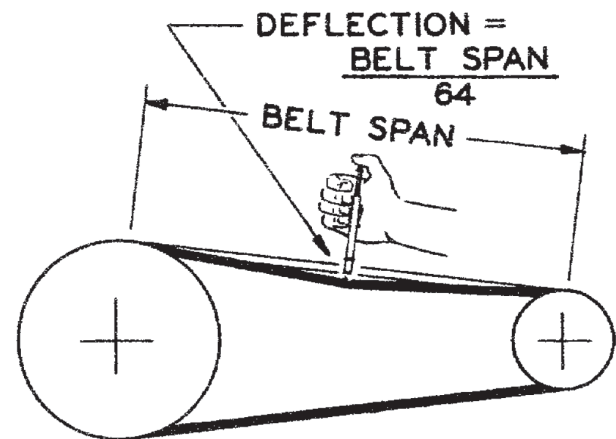

**FIG. 1 - COMPUTING DEFLECTION FORCE**  
See table below for deflection force in pounds.

## Deflection Force — Lbs.

BELT TYPE	SMALLEST SHEAVE DIAMETER RANGE	RPM RANGE	SUPER GRIPBELTS AND UNTOUCHED GRIPBANDS		GRIPNOTCHED BELTS AND NOTCHED GRIPBANDS	
			USED BELT	NEW BELT	USED BELT	NEW BELT
A, AX	3.0 - 3.6	1000 - 2500	3.7	5.5	4.1	6.1
	3.8 - 4.8	1000 - 2500	4.5	6.8	5.0	7.4
	5.0 - 7.0	1000 - 2500	5.4	8.0	5.7	9.4
B, BX	3.4 - 4.2	860 -2500	NOT RECOMMENDED		4.9	7.2
	4.4 - 5.6	860 -2500	5.3	7.9	7.1	10.5
	5.8 -8.6	860 -2500	6.3	9.4	8.5	12.6

## REPLACEMENT PARTS

Replacement parts may be ordered from the Superior Rex representative. Factory replacement parts should be used wherever possible to maintain agency listings. Should replacement parts not be purchased from the factory, use only parts duplicating the exact type, size, voltage and other operating characteristics of the original part. Contact the Superior Rex representative before using any substitute part or making unit modifications. Any substitutions and/or modifications not authorized by the factory will void the unit warranty and could result in personal injury and/or property damage.

When ordering parts, the following information must be supplied to ensure proper part identification:

1. Complete unit model number
2. CO number from the unit nameplate
3. Complete parts description, including any identification numbers.

## PIPING

- All piping must comply with applicable state and local codes.
- On water coils, the piping must be in a counterflow configuration; water inlet on the leaving air side of the coil and at the bottom of the coil to provide the necessary purging of air.
- All water piping should be designed and installed to meet the job requirements.
- Where applicable, freeze protection should be used.
- Supply and return water piping should be supported. Do not suspend piping, controls, and/or shutoff valves from coil headers.
- All refrigerant piping (split systems) should be designed and installed in accordance with AHRI and ASHRAE. Leak testing should be performed before any startup procedures are initiated. On refrigeration systems, follow recommended system evacuation from the condenser unit manufacturer.

## CONDENSATE DRAIN AND TRAPS

Drain lines should be at least the same size as the drain pan connection. Properly sized traps should be used to allow the condensate from the coils to drain from the drain pan. See Fig. 2.

**FIG. 2 - CONDENSATE DRAIN & TRAPS**

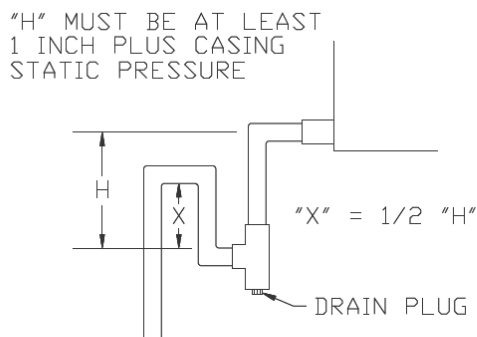

Trap detail for negative cabinet static pressure

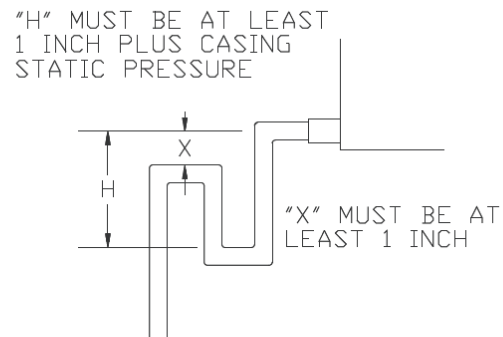

Trap detail for positive cabinet static pressure

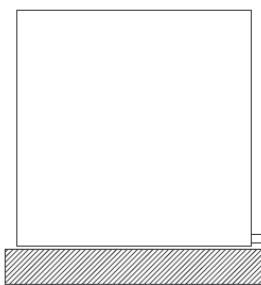

**NO BASE RAIL**

Housekeeping pad Required to accommodate trap height

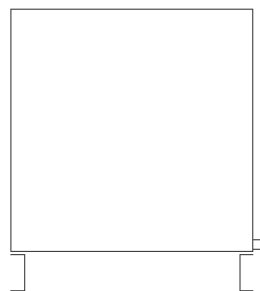

**WITH BASE RAIL**

Depending on static pressure, housekeeping pad may not be needed for trap installation

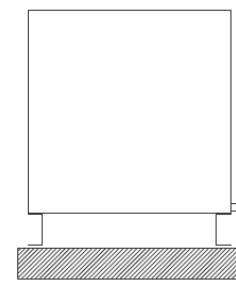

**WITH BASE RAIL AND HOUSEKEEPING PAD**

## GENERAL BELT AND BEARING MAINTENANCE

Frequency of bearing re-lubrication depends upon the operating conditions. The proper amount of lubricant in the bearings is very important. Both excessive and inadequate lubrication may cause failure. The bearings should be re-lubricated while they are rotating (if it is safe to do so); the grease should be pumped in slowly until a slight bead forms around the seals. It is solely the owner's responsibility for maintaining a proper lubrication schedule. Failure to do so may cause substantial unit damage and voiding of the factory warranty. Note that only those bearings equipped with a grease fitting can be re-lubricated.



This manual is not intended to supplant regulations or local codes having jurisdiction. It is recommended that these items be reviewed and completed prior to initiating equipment start-up.

The following is a generic guide intended for standard equipment used in common situations.

MAINTENANCE TO BE PERFORMED	EVERY 3 MONTHS OF OPERATION (MINIMUM)	EVERY FALL
FILTERS (AS REQUIRED)	X	
GREASE BEARINGS	X	
INSPECT & CLEAN BLOWER WHEEL		X
LUBRICATE FAN MOTOR (IF APPLICABLE)		X
CHECK BELT TENSION	X	
CHECK ELECTRICAL CONNECTIONS		X
CHECK BEARINGS, DRIVES 7 BLOWER WHEEL FOR TIGHTNESS		X

Normal operation is based on 8 hours a day. If unit runs more than this, adjust accordingly

RECOMMENDED TORQUE FOR TIGHTENING SETSCREWS		
SET SCREW DIAMETER	MINIMUM RECOMMENDED TORQUE	
	INCH LBS.	FOOT LBS.
#10	28	2.3
1/4	66	5.5
5/16	126	10.5
3/8	228	19.0
7/16	348	29.0
1/2	504	42.0
5/8	1104	92.0



# New Blower Coils – IOM

## MOTOR ELECTRICAL DATA

HORSEPOWER	MAXIMUM MOTOR AMPERAGE							
	VOLTAGE							
	115/1	208/1	230/1	277/1	208/3	230/3	460/3	575/3
1/3	6.3	3.5	3.2	2.6	1.7	1.5	0.8	-
1/2	7.8	4.3	3.9	3.6	2.2	2.1	1.1	0.9
3/4	10.6	5.4	5.3	5.0	3.2	3.0	1.5	1.2
1	15.0	8.3	7.5	5.5	4.0	3.6	1.8	1.4
1-1/2	-	-	-	-	5.3	5.0	2.5	1.9
2	-	-	-	-	7.0	6.4	3.2	2.5
3	-	-	-	-	9.1	9.0	4.5	3.2
5	-	-	-	-	14.2	12.8	6.4	5.2

**NOTES:**

1. Actual motor nameplate AMPs may vary, but will not exceed values shown
2. Consult Superior Rex sales representative for applications requiring special motors.

## UNIT WEIGHT DATA

COMPONENT	UNIT SIZE						
	08	12	16	20	30	40	
BASE UNIT	135 [61]	157 [71]	177 [80]	200 [90]	290 [131]	360 [163]	
DAMPER SECTION	46 [21]	54 [24]	65 [29]	90 [41]	105 [46]	162 [73]	
BLOW THROUGH ELECTRIC HEATER	42 [19]	42 [19]	42 [19]	50 [23]	55 [25]	55 [25]	
COIL ROWS	1 ROW - DRY	12 [5]	14 [6]	17 [8]	21 [10]	26 [12]	32 [15]
	1 ROW - WET	14 [6]	16 [7]	20 [9]	25 [11]	32 [15]	41 [19]
	2 ROW - DRY	17 [8]	21 [10]	26 [12]	33 [15]	42 [19]	52 [24]
	2 ROW - WET	21 [10]	26 [12]	32 [15]	42 [19]	54 [25]	69 [31]
	3 ROW - DRY	23 [10]	28 [13]	35 [16]	45 [20]	57 [26]	72 [33]
	3 ROW - WET	29 [13]	36 [16]	44 [20]	59 [27]	75 [34]	95 [43]
	4 ROW - DRY	29 [13]	35 [16]	44 [20]	57 [26]	73 [33]	91 [41]
	4 ROW - WET	37 [17]	45 [20]	56 [25]	74 [34]	96 [44]	121 [55]
6 ROW - DRY	40 [18]	49 [22]	62 [28]	81 [37]	104 [47]	132 [60]	
6 ROW - WET	52 [24]	64 [29]	81 [37]	106 [48]	138 [63]	178 [81]	

NOTE: Unit weight data is shipping weight in pounds (kilograms).

## MOTOR/DRIVE WEIGHT DATA

TYPE	MOTOR HP							
	1/3	1/2	3/4	1	1 1/2	2	3	5
SINGLE PHASE	37 [17]	37 [17]	45 [20]	47 [21]	--	--	--	--
THREE PHASE	34 [15]	34 [15]	40 [18]	43 [20]	46 [21]	53 [24]	81 [37]	94 [43]

**NOTES:**

1. Includes motor, pulleys, belts, and motor base.
2. Motor/drive weight data is shipping weight in pounds [kilograms]

MODEL SSL ARRANGEMENTS

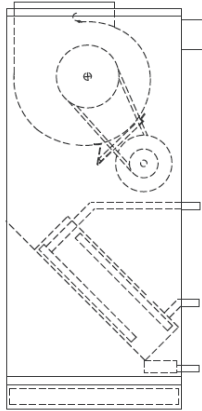

**Reverse Rotation  
Arrangement 1**

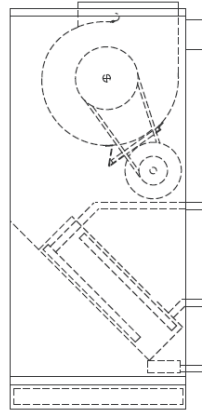

**Standard Rotation  
Arrangement 2**

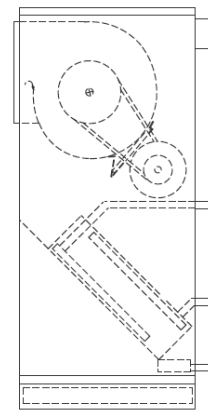

**Horizontal Rear Discharge  
Arrangement 7**

MODEL SBS ARRANGEMENTS

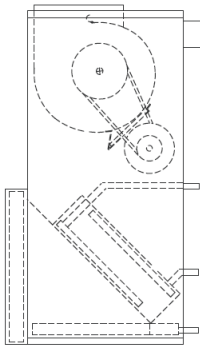

**Reverse Rotation  
Arrangement 1**

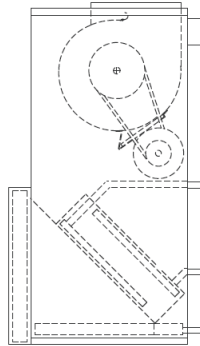

**Standard Rotation  
Arrangement 2**

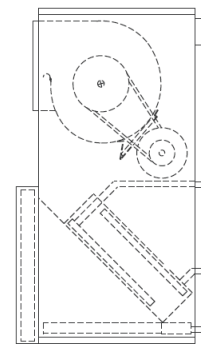

**Horizontal Rear Discharge  
Arrangement 7**

NOTES:

1. Refer to Dimensional Data for unit dimensions
2. Fan arrangements are also available with inlet damper section (Model SBS) and return plenum section (Model SSL)
3. Side access filter rack standard on arrangement 7 (Model SBS)
4. Discharge heating coil section and supply plenum are not available with arrangement 7
5. All drawings subject to change without prior notice.

## INSPECTION, INSTALLATION & START-UP CHECKLIST

### RECEIVING AND INSPECTION

- Unit Received Undamaged
- Unit Received Complete as Ordered
- Unit Arrangement Correct
- Unit Structural Support Complete & Correct

DATE:

BY:

### HANDLING & INSTALLATION

- Unit Mounted Level & Square
- Proper Access Provided for Unit and Accessories
- Proper Electrical Service Provided
- Proper Overcurrent Protection Provided
- Proper Service/Switch Disconnect Provided
- Proper Chilled Water Line Size to Unit
- Proper Hot Water Line to Unit
- All services to Unit in Code Compliance
- All Shipping Screws & Braces Removed

### COOLING/HEATING CONNECTIONS

- Protect Valve Package Components from Heat
- Mount Valve Packages
- Connect Field Piping to Unit
- Pressure test All Piping for Leaks
- Install Drain Line & Traps as Required
- Insulate all Piping as Required

### DUCTWORK CONNECTIONS

- Install Ductwork, Fittings & Grilles as Required
- Proper Supply & Return Grille Type & Size Used
- Control Outside Air for Freeze Protection
- Insulate All Ductwork as Required





# New Blower Coils – IOM

## DIMENSIONS

### Model SSL Basic Unit - Discharge Arrangement 2

**Notes:**

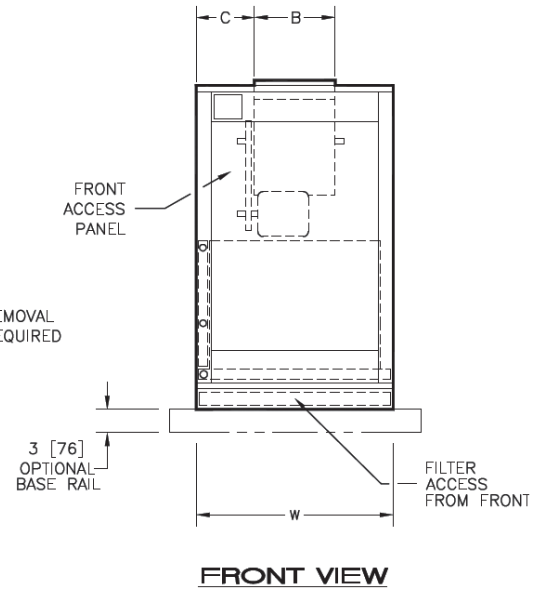
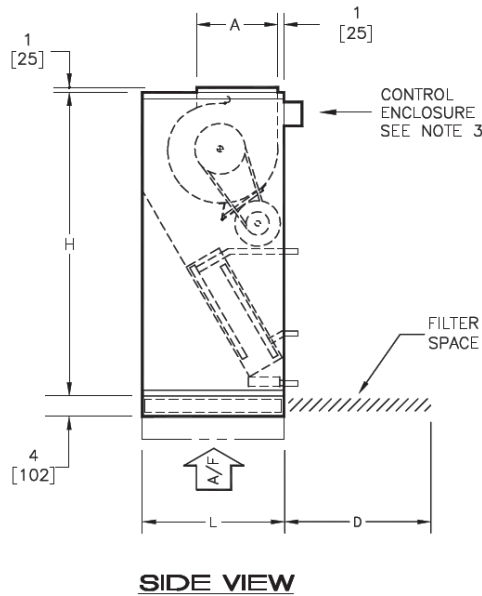
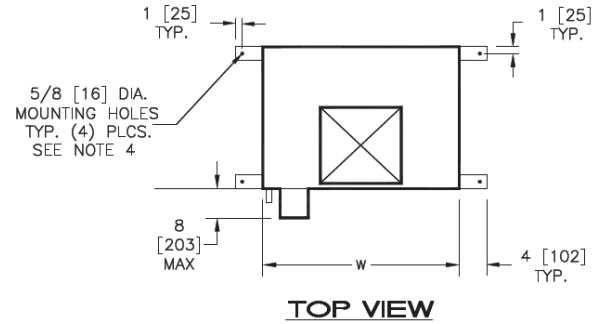
1. All dimensions are Inches [millimeters]. All dimensions  $\pm \frac{1}{4}$ " [6mm]. Metric values are soft conversion.
2. Left hand unit shown. Motor/drive location may be specified left or right hand. Standard control enclosure location matches motor/drive position. Enclosure size varies with options.
3. Provide sufficient clearance to permit access to controls and comply with applicable codes and ordinances
4. Optional base rail designed for use with floor mount vibration isolators



SIZE	FAN SIZE	QTY	H	W	L	A	B	C	D
08	16 X 20 X 2 [406 X 508 X 51]	1	46 [1168]	26 [660]	19 [483]	6-1/2 [165]	6-7/8 [175]	9-9/16 [243]	16 [406]
12	20 X 20 X 2 [508 X 508 X 51]	1	46 [1168]	26 [660]	21 [533]	7-1/2 [190]	8-1/4 [210]	8-7/8 [226]	20 [508]
16	24 X 20 X 2 [610 X 508 X 51]	1	54 [1372]	29 [737]	25 [635]	7-1/2 [190]	10-1/4 [260]	9-3/8 [238]	24 [610]
20	24 X 24 X 51 [610 X 610 X 51]	1	54 [1372]	29 [737]	28 [711]	11-3/8 [289]	13-1/4 [337]	7-7/8 [200]	24 [610]
25	24 X 24 X 51 [610 X 610 X 51]	1 EACH	60 [1524]	39 [991]	28 [711]	16 [406]	12-7/8 [327]	13-1/16 [332]	24 [610]
30	12 X 24 X 2 [305 X 610 X 51]	1 EACH	60 [1524]	39 [991]	28 [711]	16 [406]	15 [381]	12 [305]	24 [610]

## DIMENSIONS

### Model SSL Basic Unit - Discharge Arrangement 1 with Blow-thru Electric Heat

**Notes:**

1. All dimensions are Inches [millimeters]. All dimensions  $\pm \frac{1}{4}$ " [6mm]. Metric values are soft conversion.
2. Left hand unit shown. Motor/drive location may be specified left or right hand. Standard control enclosure location matches motor/drive position. Enclosure size varies with options.
3. Provide sufficient clearance to permit access to controls and comply with applicable codes and ordinances
4. Optional base rail designed for use with floor mount vibration isolators

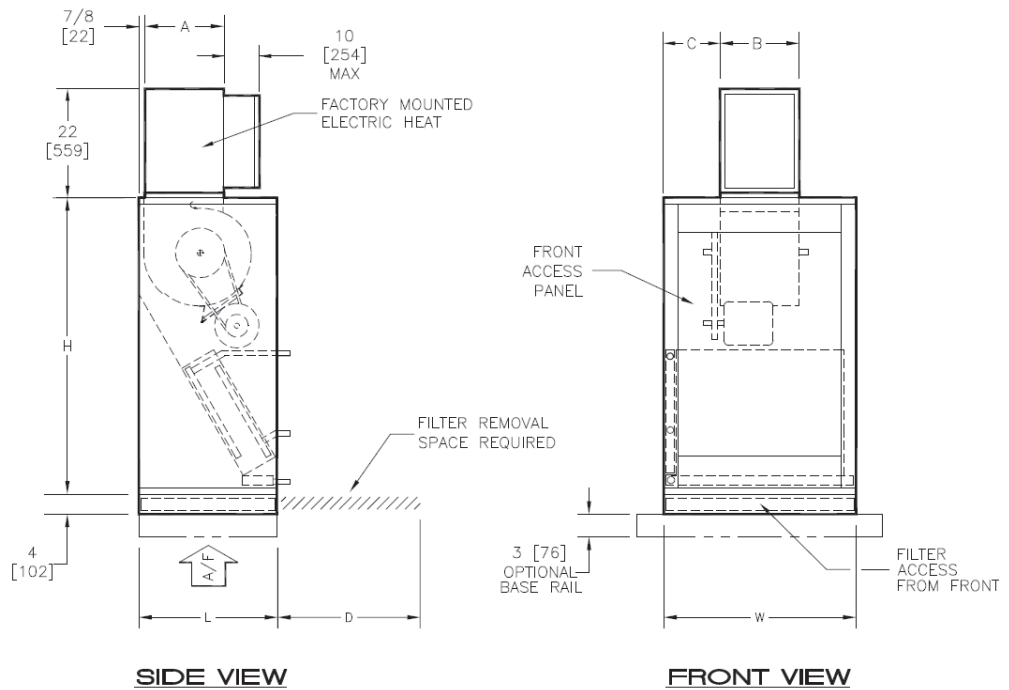
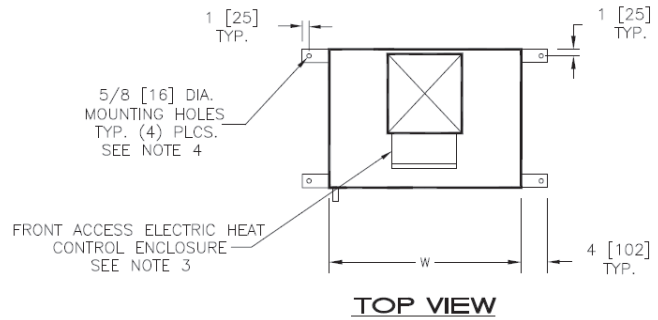

SIZE	FAN SIZE	QTY	H	W	L	A	B	C	D
08	16 X 20 X 2 [406 X 508 X 51]	1	46 [1168]	26 [660]	19 [483]	6-1/2 [165]	6-7/8 [175]	9-9/16 [243]	16 [406]
12	20 X 20 X 2 [508 X 508 X 51]	1	46 [1168]	26 [660]	21 [533]	7-1/2 [190]	8-1/4 [210]	8-7/8 [226]	20 [508]
16	24 X 20 X 2 [610 X 508 X 51]	1	54 [1372]	29 [737]	25 [635]	7-1/2 [190]	10-1/4 [260]	9-3/8 [238]	24 [610]
20	24 X 24 X 51 [610 X 610 X 51]	1	54 [1372]	29 [737]	28 [711]	11-3/8 [289]	13-1/4 [337]	7-7/8 [200]	24 [610]
25	24 X 24 X 51 [610 X 610 X 51]	1 EACH	60 [1524]	39 [991]	28 [711]	16 [406]	12-7/8 [327]	13-1/16 [332]	24 [610]
30	12 X 24 X 2 [305 X 610 X 51]	1 EACH	60 [1524]	39 [991]	28 [711]	16 [406]	15 [381]	12 [305]	24 [610]

# New Blower Coils – IOM

## DIMENSIONS

### Model SBS Basic Unit - Discharge Arrangement 2

**Notes:**

1. All dimensions are Inches [millimeters]. All dimensions  $\pm 1/4"$  [6mm]. Metric values are soft conversion.
2. Left hand unit shown. Motor/drive location may be specified left or right hand. Standard control enclosure location matches motor/drive position. Enclosure size varies with options.
3. Provide sufficient clearance to permit access to controls and comply with applicable codes and ordinances
4. Optional base rail designed for use with floor mount vibration isolators

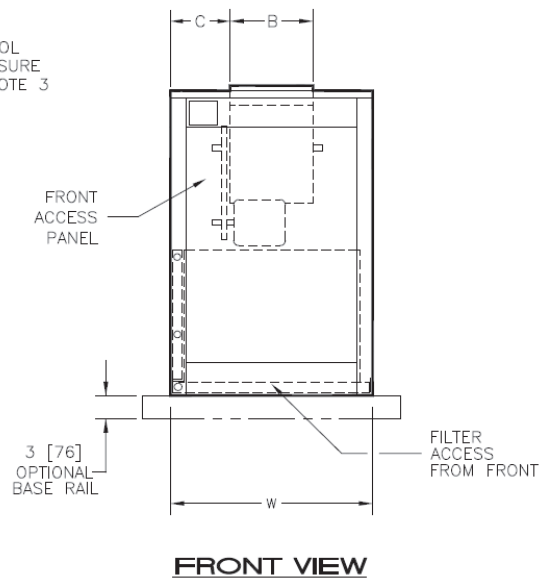
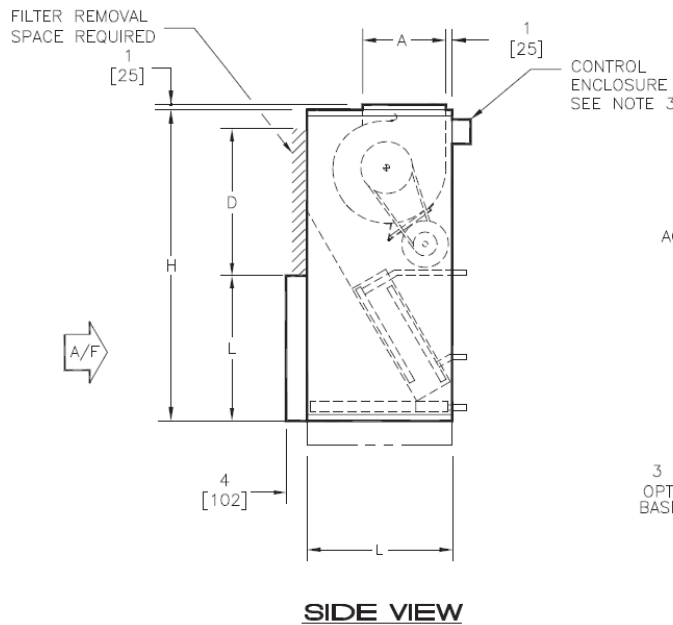
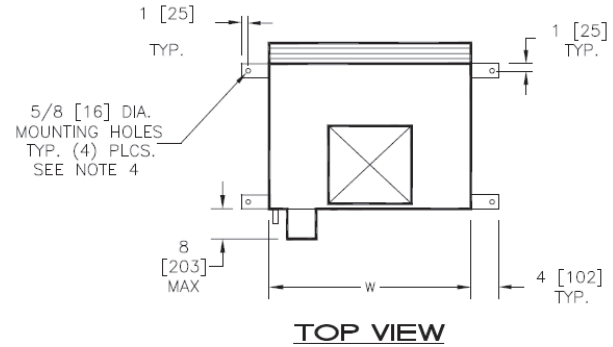

SIZE	FAN SIZE	QTY	H	W	L	A	B	C	D
08	16 X 20 X 2 [406 X 508 X 51]	1	46 [1168]	26 [660]	19 [483]	6-1/2 [165]	6-7/8 [175]	9-9/16 [243]	16 [406]
12	20 X 20 X 2 [508 X 508 X 51]	1	46 [1168]	26 [660]	21 [533]	7-1/2 [190]	8-1/4 [210]	8-7/8 [226]	20 [508]
16	24 X 20 X 2 [610 X 508 X 51]	1	54 [1372]	29 [737]	25 [635]	7-1/2 [190]	10-1/4 [260]	9-3/8 [238]	24 [610]
20	24 X 24 X 51 [610 X 610 X 51]	1	54 [1372]	29 [737]	28 [711]	11-3/8 [289]	13-1/4 [337]	7-7/8 [200]	24 [610]
25	24 X 24 X 51 [610 X 610 X 51]	1 EACH	60 [1524]	39 [991]	28 [711]	16 [406]	12-7/8 [327]	13-1/16 [332]	24 [610]
30	12 X 24 X 2 [305 X 610 X 51]	1 EACH	60 [1524]	39 [991]	28 [711]	16 [406]	15 [381]	12 [305]	24 [610]

## DIMENSIONS

Model SSL/SBS with Mixing Box and Inlet Damper Section (Requires Base Rail) -Discharge Arrangement 2

**Notes:**

1. All dimensions are Inches [millimeters]. All dimensions  $\pm 1/4"$  [6mm]. Metric values are soft conversion.
2. Left hand unit shown. Motor/drive location may be specified left or right hand. Standard control enclosure location matches motor/drive position. Enclosure size varies with options.
3. Provide sufficient clearance to permit access to controls and comply with applicable codes and ordinances
4. Optional base rail designed for use with floor mount vibration isolators

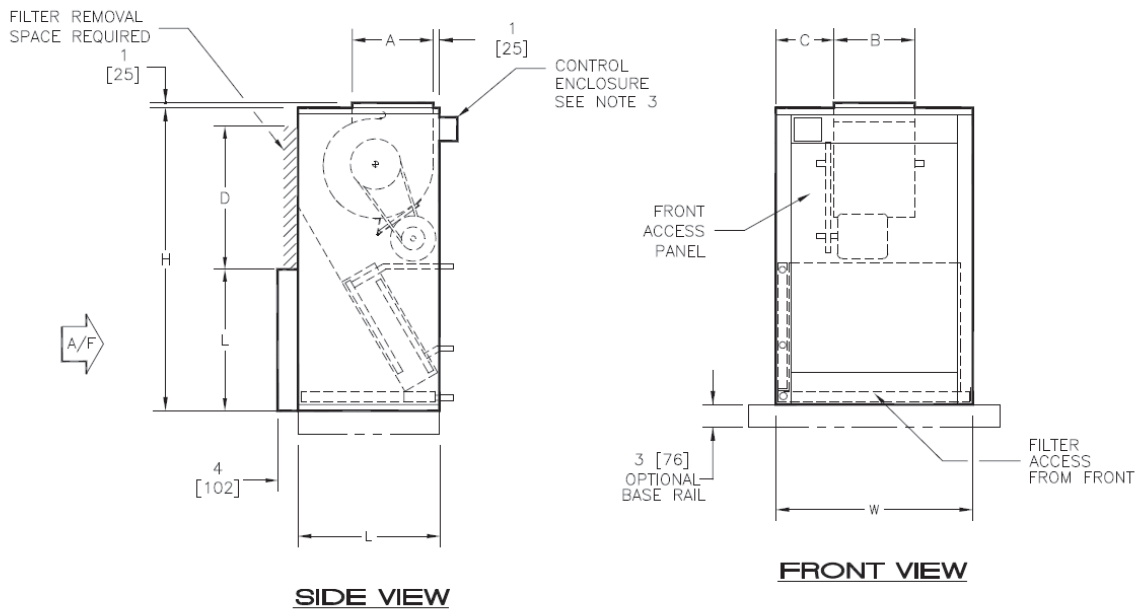
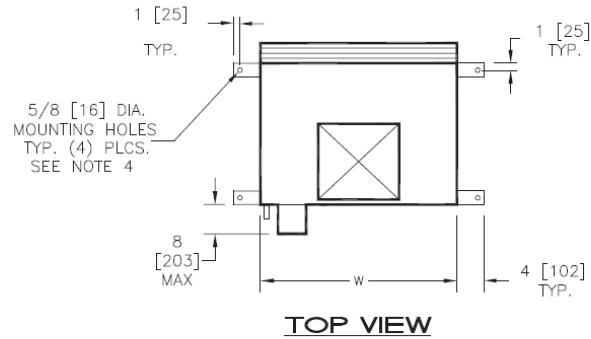

SIZE	FAN SIZE	QTY	H	W	L	A	B	C	D	E	F	G	J
08	16 X 20 X 2 [406 X 508 X 51]	1	46 [1168]	26 [660]	19 [483]	6-1/2 [165]	6-7/8 [175]	9-9/16 [243]	16 [406]	15 [381]	35 [889]	6 [152]	22 [559]
12	20 X 20 X 2 [508 X 508 X 51]	1	46 [1168]	26 [660]	21 [533]	7-1/2 [190]	8-1/4 [210]	8-7/8 [226]	20 [508]	18 [457]	40 [1016]	9 [229]	22 [559]
16	24 X 20 X 2 [610 X 508 X 51]	1	54 [1372]	29 [737]	25 [635]	7-1/2 [190]	10-1/4 [260]	9-3/8 [238]	24 [610]	18 [457]	44 [1118]	9 [229]	25 [635]
20	24 X 24 X 51 [610 X 610 X 51]	1	54 [1372]	29 [737]	28 [711]	11-3/8 [289]	13-1/4 [337]	7-7/8 [200]	24 [610]	21 [533]	50 [1270]	12 [305]	25 [635]
25	24 X 24 X 51 [610 X 610 X 51]	1 EACH	60 [1524]	39 [991]	28 [711]	16 [406]	12-7/8 [327]	13-1/16 [332]	24 [610]	21 [533]	50 [1270]	12 [305]	35 [889]
30	12 X 24 X 2 [305 X 610 X 51]	1 EACH	60 [1524]	39 [991]	28 [711]	16 [406]	15 [381]	12 [305]	24 [610]	21 [533]	50 [1270]	12 [305]	35 [889]



# New Blower Coils – IOM

## 3 Inch Baserail Assembly

**Notes:**

1. All dimensions are Inches [millimeters]. All dimensions  $\pm \frac{1}{4}$ "
2. Vertical unit shown, typical for both vertical and horizontal units
3. Support used on units with length over 50 [1270]

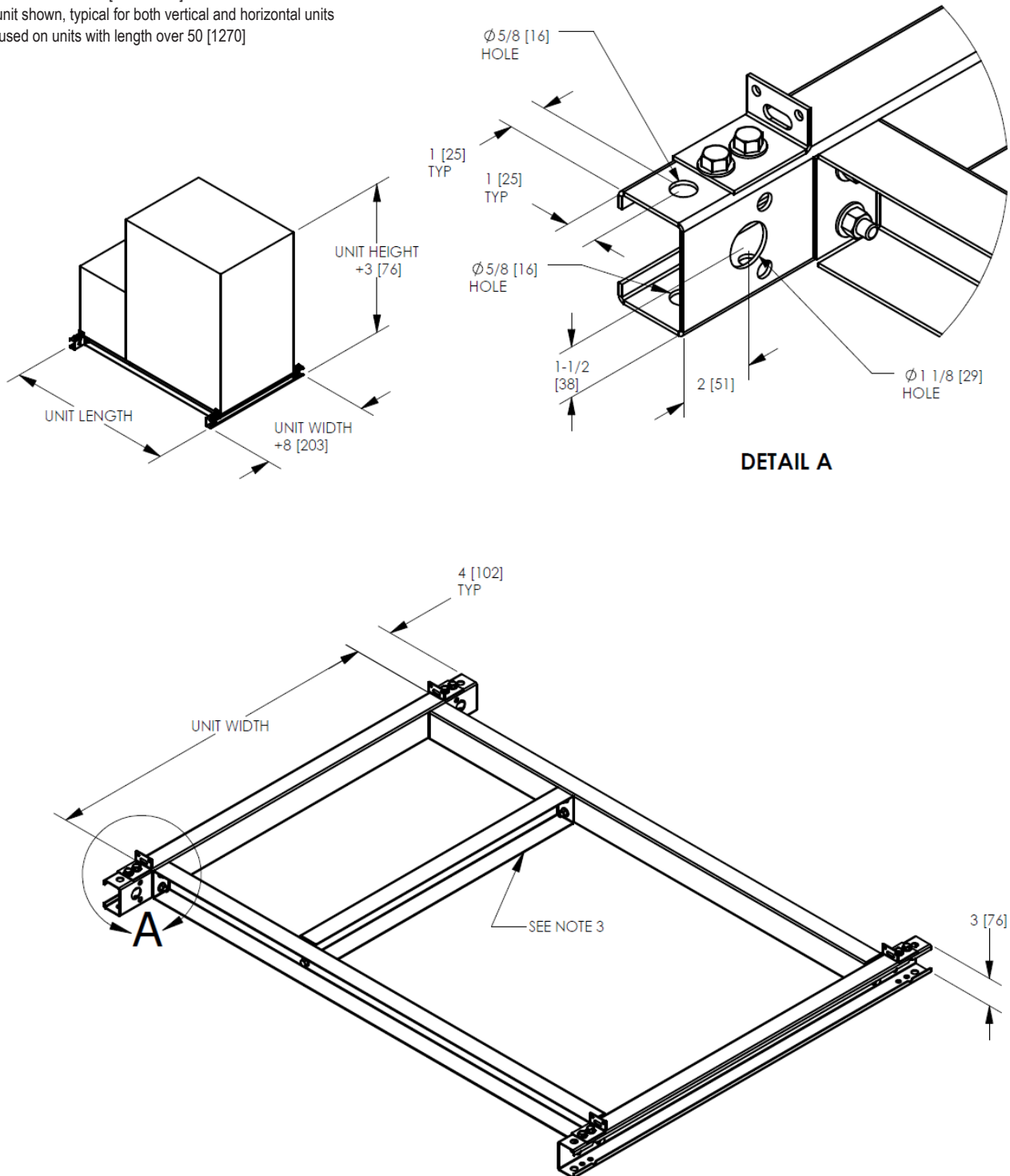

## Model SSL/SBS Discharge Plenum

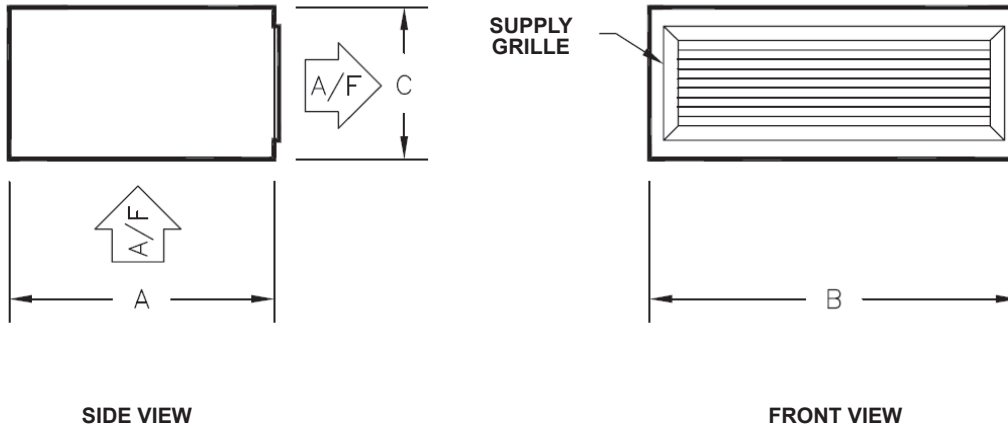

UNIT SIZE	A	B	C	SUPPLY GRILLE
08	19 [483]	26 [660]	12 [305]	18 X 8 [457 X 203]
12	21 [533]	26 [660]	12 [305]	22 X 8 [559 X 203]
16	25 [635]	29 [737]	14 [356]	24 X 10 [610 X 254]
20	28 [711]	29 [737]	16 [406]	24 X 12 [610 X 305]
30	28 [711]	39 [991]	16 [406]	30 X 12 [762 X 305]
40	28 [711]	39 [991]	16 [406]	36 X 12 [914 X 305]

**Notes:**

1. All dimensions are Inches [millimeters]. All dimensions  $\pm 1/4"$  [6mm]. Metric values are soft conversion.
2. Discharge plenum shipped attached to unit
3. Discharge plenum includes a double deflection discharge grille
4. Discharge plenum may not be combined with Blow-thru electric heat

# New Blower Coils – IOM



## Model SSL Return Plenum

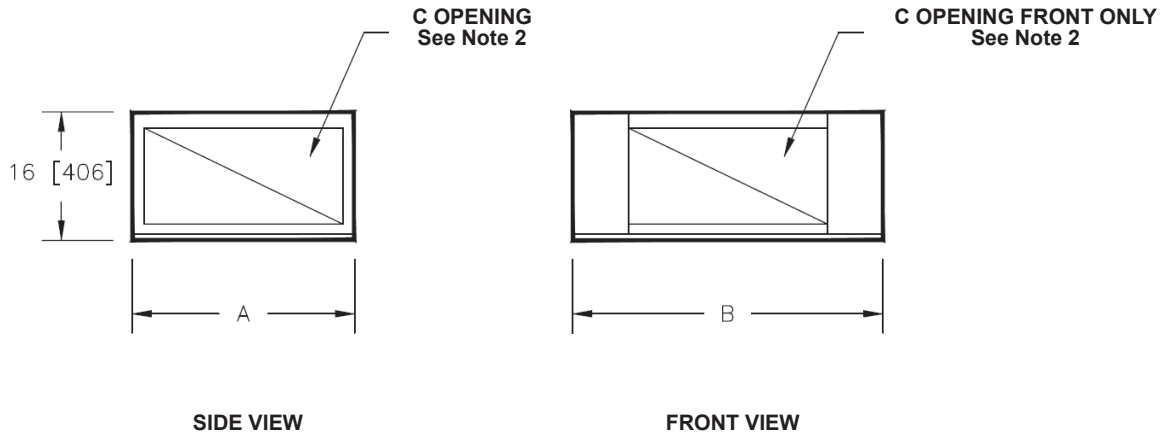

UNIT SIZE	A	B	C OPENING
08	19 [483]	26 [660]	9 X 16 [229 X 406]
12	21 [533]	26 [660]	9 X 18 [229 X 457]
16	25 [635]	29 [737]	9 X 22 [229 X 559]
20	28 [711]	29 [737]	12 X 22 [305 X 559]
30	28 [711]	39 [991]	12 X 25 [305 X 635]
40	28 [711]	39 [991]	12 X 25 [305 X 635]

**Notes:**

1. All dimensions are Inches [millimeters]. All dimensions  $\pm 1/4"$  [6mm]. Metric values are soft conversion.
2. Standard plenum is provided with removable covers on side openings, and plenum is installed on unit for front inlet. Covers may be relocated, and plenum may be relocated in the field for alternate inlet locations.

## Model SSL/SBS Discharge Section w/ Heating Coil

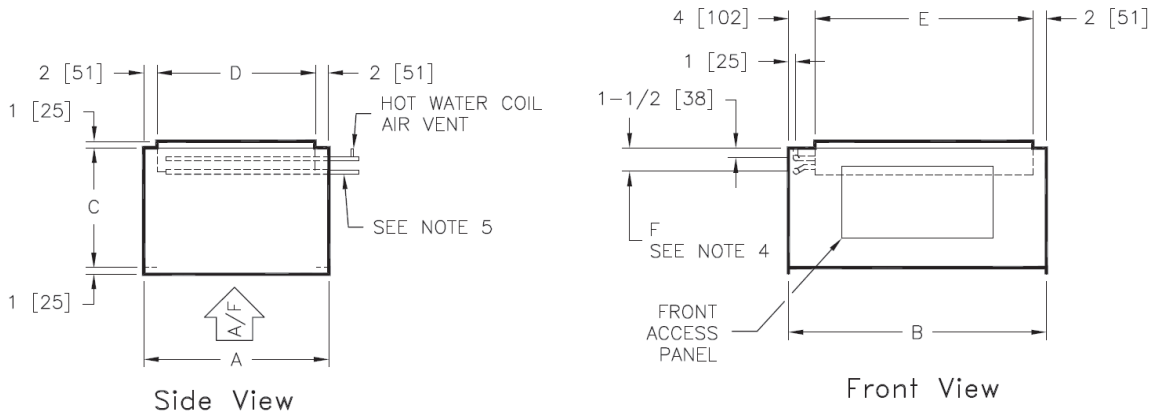

**Notes:**

1. All dimensions  $\pm 1/4"$  [6mm].
2. This section required with 6 new cooling in conjunction with hot water and all steam heating.
3. Weight with 2 row dry coil
4. Coil Connection dimension  $\pm 1/4"$  [13mm]
5. Hot water coils: Supply – top, condensate – bottom
6. Discharge section may not be combined with Blow-thru Electric Heat

UNIT SIZE	A	B	C	D	E	F (4)				WGT. (3) lbs. [kg]
						HOT WATER		STEAM		
						1 ROW	2 ROW	1 ROW	2 ROW	
08	19 [483]	26 [660]	12 [305]	15 [381]	20 [508]	2-3/4 [70]	2-3/4 [70]	2-3/4 [70]	2-3/4 [70]	35 [16]
12	21 [533]	26 [660]	12 [305]	17 [432]	20 [508]	2-3/4 [70]	2-3/4 [70]	2-3/4 [70]	2-3/4 [70]	37 [17]
16	25 [635]	29 [737]	14 [356]	21 [533]	23 [584]	2-3/4 [70]	3 [76]	2-3/4 [70]	3-1/4 [83]	49 [22]
20	28 [711]	29 [737]	14 [356]	24 [610]	23 [584]	2-3/4 [70]	3 [76]	3-1/4 [83]	3-1/4 [83]	53 [24]
25	28 [711]	39 [991]	18 [457]	24 [610]	33 [838]	2-3/4 [70]	3 [76]	3-1/4 [83]	3-3/4 [95]	76 [35]
30	28 [711]	39 [991]	18 [457]	24 [610]	33 [838]	3 [76]	3-1/4 [83]	3-1/4 [83]	3-3/4 [95]	80 [36]

## Coil Connection Sizes

UNIT SIZE	HOT WATER		STEAM			
			1 ROW		2 ROW	
			SUPPLY	CONDENSATE	SUPPLY	CONDENSATE
08	5/8 [16]	5/8 [16]	1-1/8 [29]	7/8 [22]	1-1/8 [29]	7/8 [22]
12	5/8 [16]	5/8 [16]	1-1/8 [29]	7/8 [22]	1-1/8 [29]	7/8 [22]
16	5/8 [16]	5/8 [16]	1-1/8 [29]	7/8 [22]	1-3/8 [35]	1-1/8 [29]
20	5/8 [16]	5/8 [16]	1-3/8 [35]	1-1/8 [29]	1-3/8 [35]	1-1/8 [29]
25	5/8 [16]	7/8 [22]	1-3/8 [35]	1-1/8 [29]	1-5/8 [41]	1-1/8 [29]
30	7/8 [22]	7/8 [22]	1-5/8 [41]	1-1/8 [29]	1-5/8 [41]	1-1/8 [29]

# New Blower Coils – IOM





# New Blower Coils – IOM

# New Blower Coils – IOM



