

**SBHD Dual Blower Arr. 3 w/Mixing Box & Electric Heat**

Model SBHD Direct Drive Dual Blower Coil Unit Discharge ARGT. 3  
w/ Mixing Box & Blow-Thru Electric Heat

**NOTES:**

1. All dimensions are Inches [millimeters]. All dimensions are  $\pm 1/4"$  [6mm]. Metric Values are soft conversion.
2. Right hand unit shown, left hand unit opposite. Motor/drive location may be specified Left or Right Hand. Standard control enclosure location matches motor/drive position.
3. Provide sufficient clearance to permit access To controls and comply with applicable codes and ordinances.
4. See drawing BC-SBHD-16.0 for filter rack details.
5. Base rail is optional on the base unit. See Drawing BC-SBHD-18.0. Base rails must be used With mixing box.
6. See coil connection details drawings for coil connection sizes and locations.

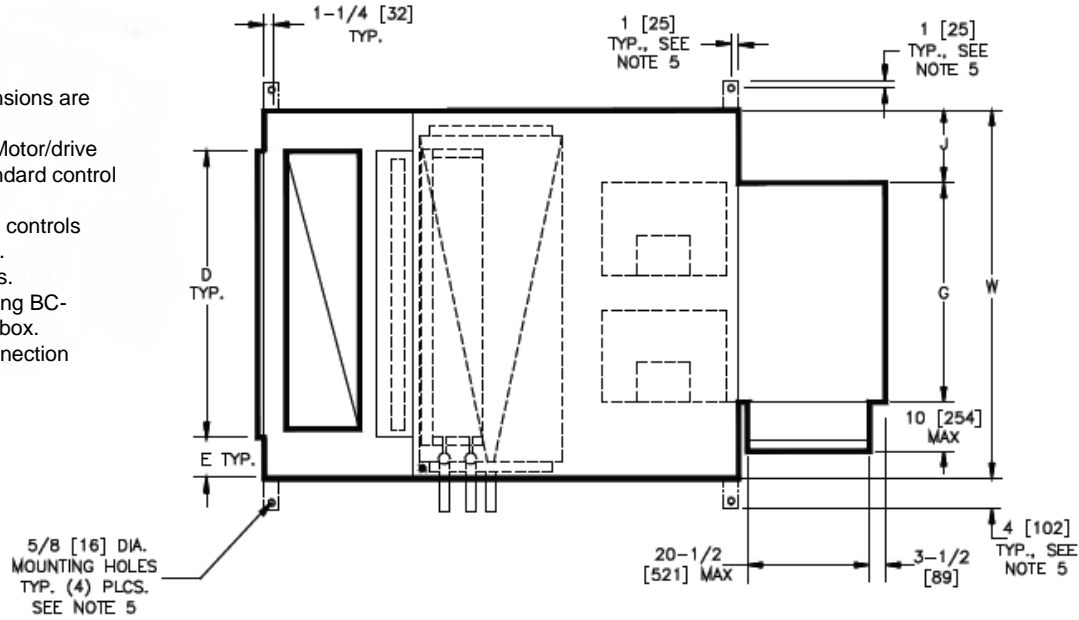

**TOP VIEW**

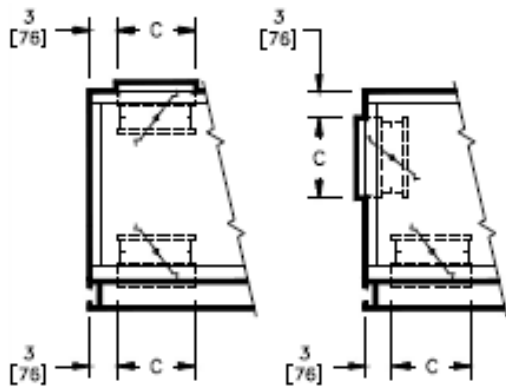

**TOP/BTM INLET**

**REAR/BTM INLET**

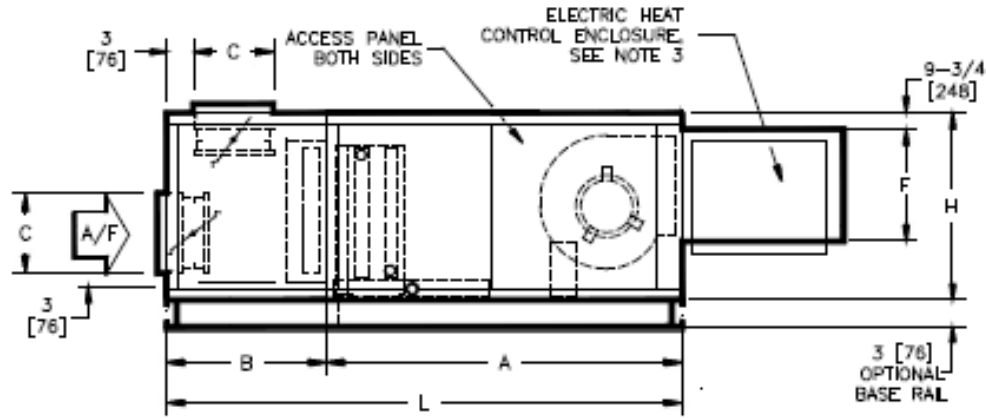

**REAR/TOP INLET**

**SIDE VIEW**

**DIMENSIONS**

SIZE	FAN SIZE	L	W	H	A	B	C	D	E	F	G	J
30	10 X 8 [254 X 203]	67 [1702]	59 [1499]	30 [762]	46 [1168]	21 [533]	12 [305]	45 [1143]	7 [178]	12 [305]	34-1/4 [870]	12-3/8 [314]
40	10 X 8 [254 X 203]	70 [1778]	68 [1727]	30 [762]	46 [1168]	24 [610]	15 [381]	48 [1219]	10 [254]	12 [305]	34-1/4 [870]	16-7/8 [429]

New	08/04/22	SP	New Release
Revision Date	Version Date	Initiated By	Description