

## SBVD Dual Blower Arr. 3 & Mixing Box

Direct Drive Dual Blower Coil Unit Discharge  
ARGT. 3 w/Mixing Box

**NOTES:**

1. All dimensions are Inches [millimeters]. All dimensions are  $\pm 1/4"$  [6mm]. Metric values are soft conversion.
2. Right hand unit shown, left hand unit opposite. Motor/drive location may be specified Left or Right Hand. Standard control enclosure location matches motor/drive position.
3. Provide sufficient clearance to permit access to controls and comply with applicable codes and ordinances.
4. See drawing BC-SBHD-16.0 for filter rack details.
5. Base rail is optional on the base unit. See drawing BC-SBHD-18.0. Base rails must be used with mixing box.
6. See coil connection details drawings for Coil connection sizes and locations.

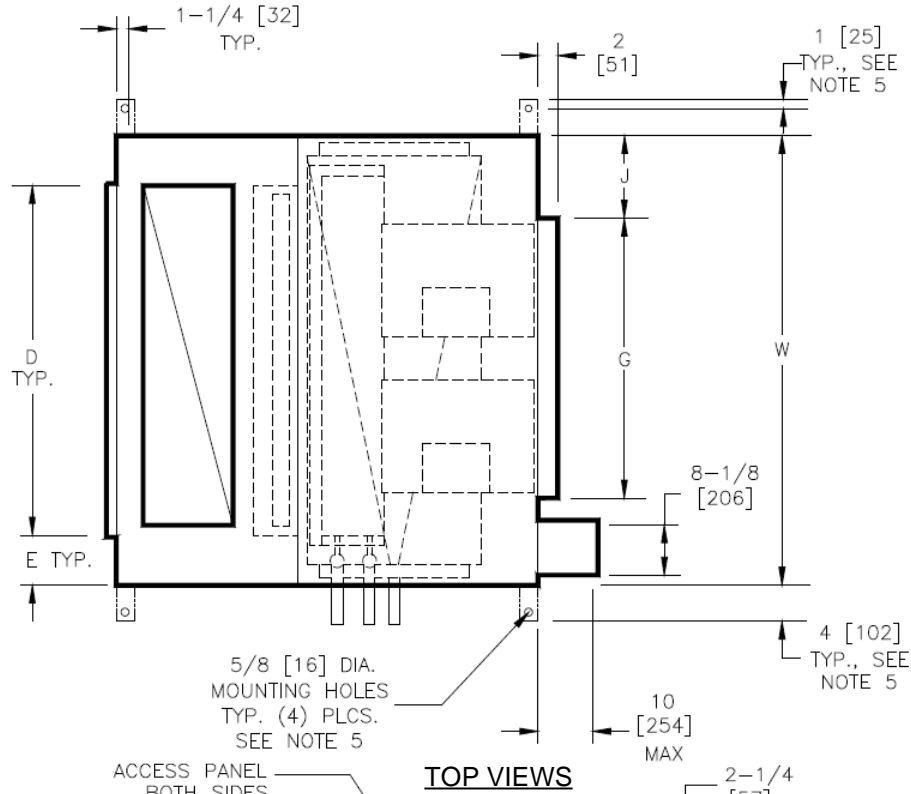

**TOP VIEWS**

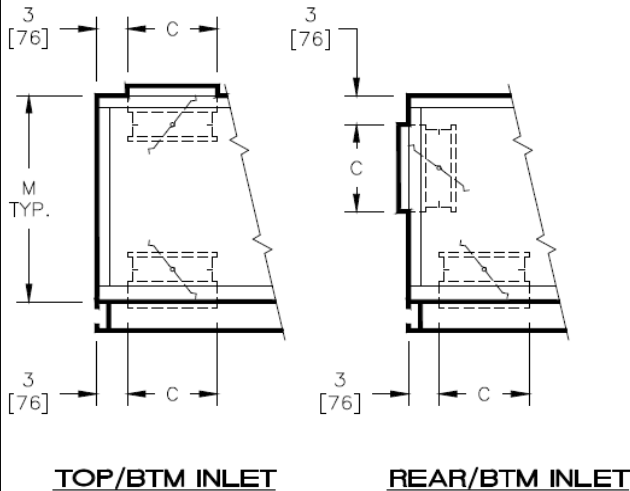

**TOP/BTM INLET**

**REAR/BTM INLET**

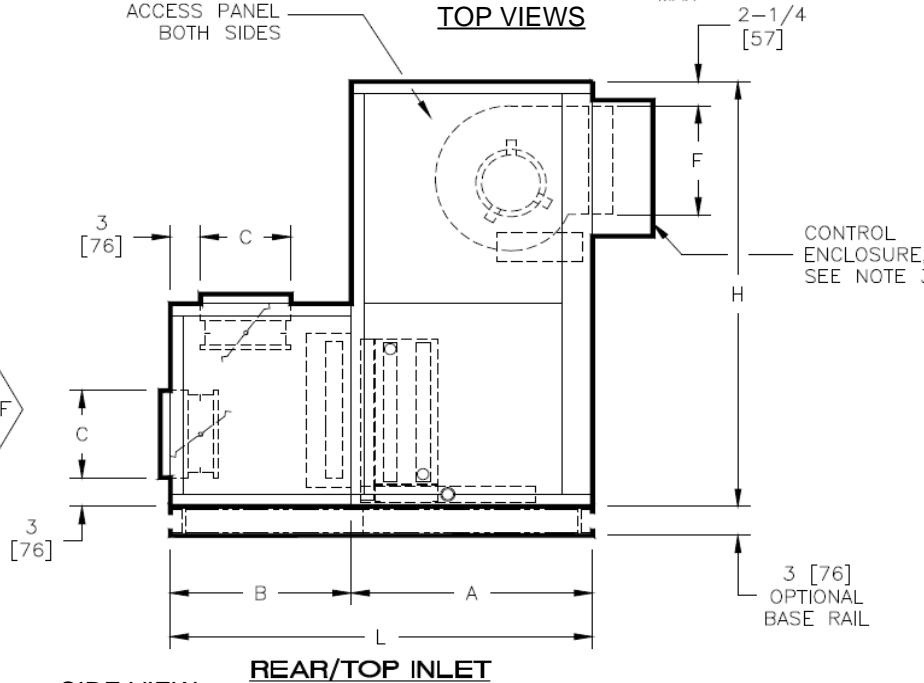

**SIDE VIEW**

**REAR/TOP INLET**

**DIMENSIONS**

SIZE	UNIT MODEL	L	W	H	A	B	C	D	E	F	G	J	M
30	10 X 8	51	59	56	30	21	12	45	7	18	36-1/2	11-1/4	30
	[254 X 203]	[1295]	[1499]	[1422]	[762]	[533]	[305]	[1143]	[178]	[457]	[927]	[286]	[762]
40	10 X 8	54	68	59	30	24	15	48	10	18	36-1/2	15-3/4	30
	[254 X 203]	[1372]	[1727]	[1499]	[762]	[610]	[381]	[1219]	[254]	[457]	[927]	[400]	[762]

New	08/04/22	SP	New Release
Revision Date	Version Date	Initiated By	Description