

**SBVD Dual Blower Arr. 2**

Model SBVD Direct Drive Dual Blower Coil  
Unit Basic Unit- Discharge ARGT. 2

**NOTES:**

1. All dimensions are Inches [millimeters]. All dimensions are  $\pm 1/4"$  [6mm]. Metric values are soft conversion.
2. Right hand unit shown, left hand unit opposite. Motor/drive location may be specified Left or Right Hand. Standard control enclosure location matches motor/drive position.
3. Provide sufficient clearance to permit access to controls and comply with applicable codes and ordinances.
4. See drawing BC-SBHD-16.0 for filter rack details.
5. Base rail is optional on the base unit. See drawing BC-SBHD-18.0. Base rails must be used with mixing box.
6. See coil connection details drawings for Coil connection sizes and locations.

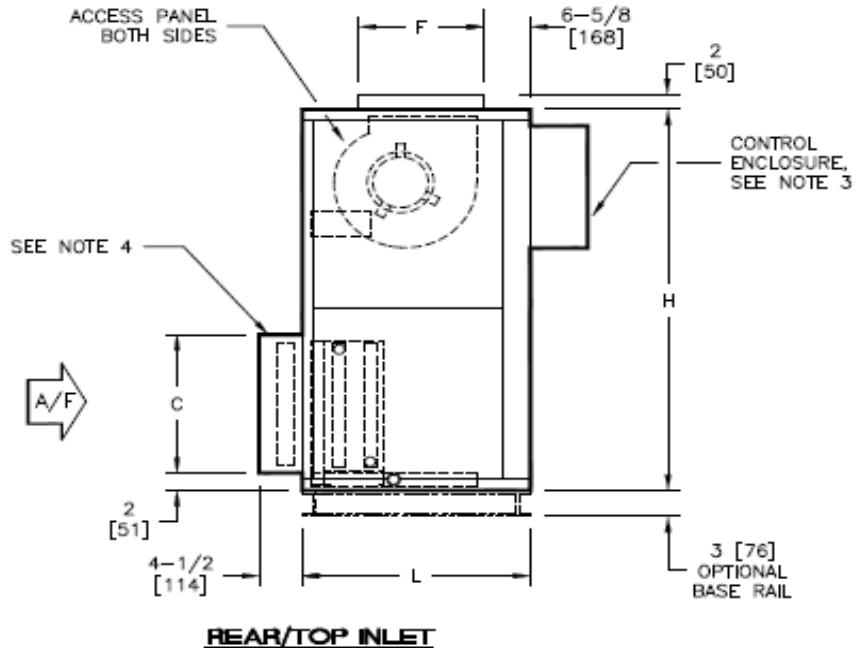
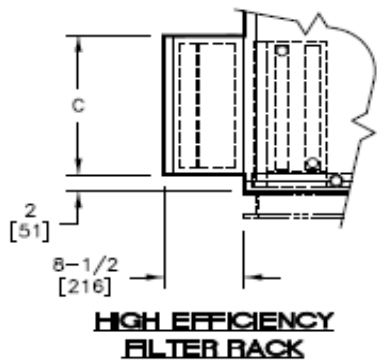
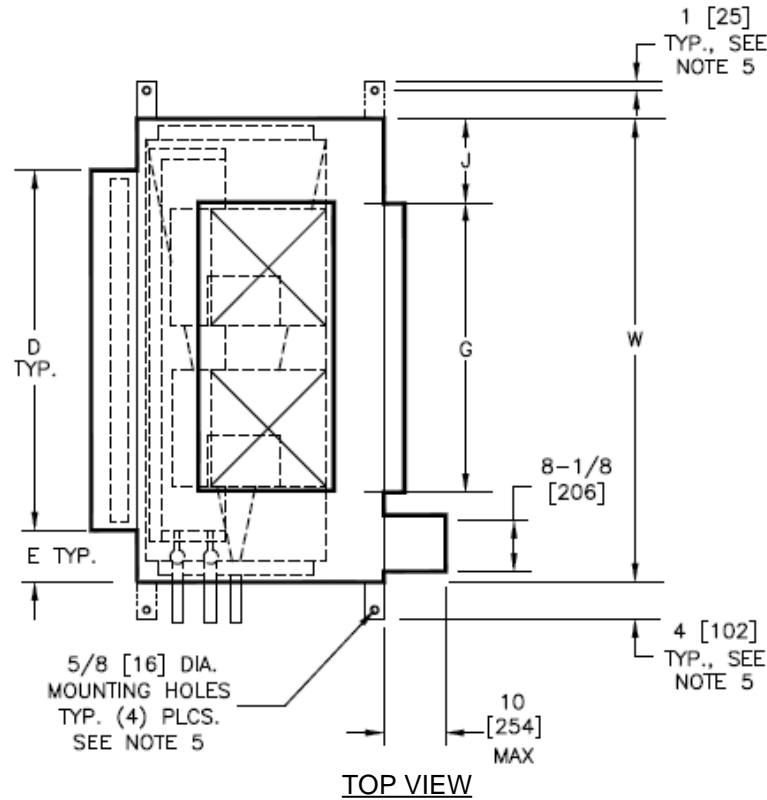

**SIDE VIEW**

**DIMENSIONS**

SIZE	UNIT MODEL	L	W	H	C	D	E	F	G	J
30	10 X 8	30	59	56	25	51	4	18	36-1/2	11-1/4
	[254 X 203]	[762]	[1499]	[1422]	[635]	[1295]	[102]	[457]	[927]	[286]
40	10 X 8	30	68	59	25	59	4-1/2	18	36-1/2	15-3/4
	[254 X 203]	[762]	[1727]	[1499]	[635]	[1499]	[114]	[457]	[927]	[400]

New	08/04/22	SP	New Release
Revision Date	Version Date	Initiated By	Description